

MIRRICO

GROUP OF COMPANIES

MARTin

Mobile autonomous robotic complex for tank cleaning, oilfield and petrochemical equipment

- Services for cleaning of: tanks, oilfield and petrochemical equipment, tankers and railway tanks.
- MARTin equipment sale.
- Warranty maintenance.

mirrico.ru



Technological effectiveness
and mobility

Performance specifications of MARTin complex

Dimensions and weight of the complex	<ul style="list-style-type: none"> • Two trailers of the same size and weight: <ul style="list-style-type: none"> – L – 12,25 m – H – 3,96 m – B – 2,44 m • 40-foot container for auxiliary equipment
Extracted residue output	not less than 10,0 m ³ per hour
Operating temperature	from –35 to +50 °C
Hot water pressure of washing	20,7 bar upon consumption of 68 m ³ per hour
Equipment drives type	fluid drive
Power supply of the complex	autonomous diesel generator
Installation time	4–6 hours
Necessary staff	5 persons

* MARTin is destined for cleaning of the equipment with a volume up to 50 000 m³ from residues followed by slime processing and disposal.



Content of the equipment and technology

MARTin complex basic equipment consists of three units, each of which can be equipped with different equipment, based on the Customer's requirements and conditions. The fourth unit for disposal (decontamination) of oil waste and water treatment is under development by the MIRRICO Group of Companies.

1. Unit of bottom sediments extraction and cleaning of inner surfaces from oil sediments

A remodeled mobile 20-foot sea container equipped with lighting, heating and air conditioning systems. The container is divided into two compartments (an operator's room and a compartment for storage and transportation of auxiliary equipment). The operator's room is equipped with operator's work place, control systems for robotic devices, video surveillance and warning. The compartment for storage and transportation of auxiliary equipment is equipped with a hydraulic station, a place for a robotic cleaner and a robotic gun, as well as with auxiliary equipment (hoses, hydraulic gangway, nozzles, flow meters, etc.) and instrumentation system. All equipment is certified and flame and explosion-proof.

The equipment is placed on the 12 meter trailer and is equipped with a process tank with a set containing a heat-exchanger, washing pump and level gauges etc.

The space is equipped with warning and conditioning systems and allows to perform work at a temperature from -30 до +45 °C.

Pos.	Item description	Meas. unit	Quantity
1	Semi-trailer	pc	1
2	20-foot container	pc	1
3	1 TsGNSg 38-176 pump	pc	1
4	Ground with barrier railings	set	1
5	Main fuel tank (for water heating burner)	pc	1
6	Container for storage and heating of water	pc	1
7	Lamborghini ECO-30 diesel burner, 190-356 kWt, with heat-exchanger	set	1
8	KM40-32-160-E fuel pump	pc	1
9	Fuel gravity tank (V=200 l)	pc	1
10	Cabinet	pc	1
11	Fan	pc	1
12	Robot container (operator's room)	pc	1
13	Ramp for robot movement	pc	2
14	Control unit	pc	1
15	Robot	pc	1

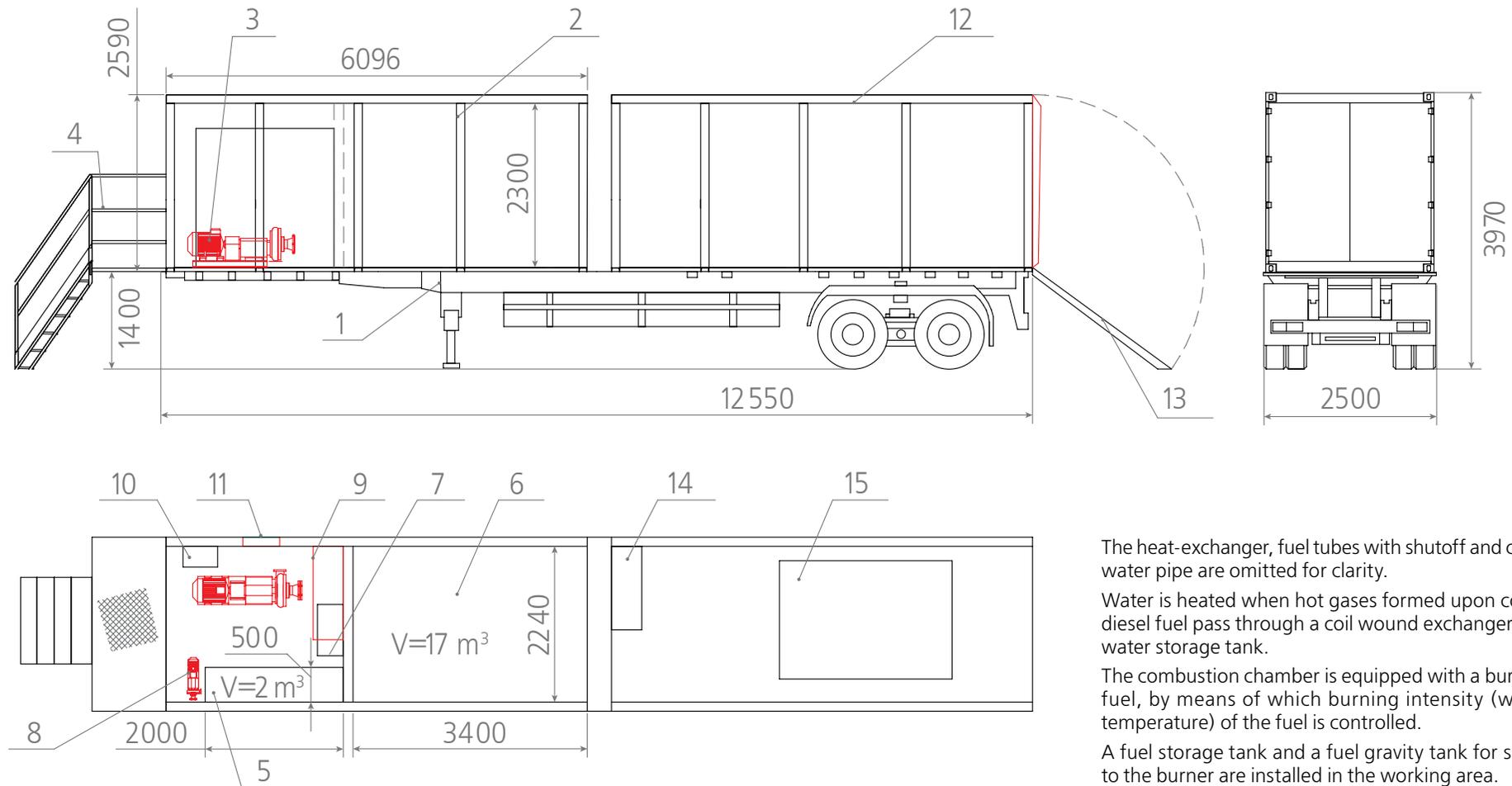

The heat-exchanger, fuel tubes with shutoff and control valves, water pipe are omitted for clarity.

Water is heated when hot gases formed upon combustion of diesel fuel pass through a coil wound exchanger installed in a water storage tank.

The combustion chamber is equipped with a burner for diesel fuel, by means of which burning intensity (water heating temperature) of the fuel is controlled.

A fuel storage tank and a fuel gravity tank for supplying fuel to the burner are installed in the working area.

Utility modules are insulated with mineral wool of 50 mm.

Content of the equipment and technology

2. Unit of cleaning and processing (phase separation) of sediments

The basic equipment consists of a set of equipment and devices (tanks, hydraulic cyclones, dehydrators, tricanter, pumps, stirrers, screw conveyors, electric diesel station, bandaging material and instrumentation system). All equipment is located in a specially designed room, which has the dimensions of a 40-foot sea container positioned on its own chassis for transport. The container's design allows to double the useful area of the space in 15 minutes in the operating mode.

The space is equipped with lighting, heating and air conditioning systems and allows you to work at a temperature from -30 до $+45$ °C.



Pos.	Item description	Quantity
1	Flexible slurry pipeline with quick release	1
2	Dehydrator	1
3	Concrete pump	1
4	Centrifuge	1
5	Water-oil emulsion collection tank $V=7$ m ³	1
6	CAB semi-trailer	1
7	Centrifuge pump	1
8	CM80-50-200-4 pump	1
9	Ladder	1
10	KO vacuum pump	1
11	220 kWt diesel power station	1
12	KM water pipe	1
13	Water capacity $V=1$ m ³	1
14	SRRf flocculation station 500 m	1
15	Insulated container	1
16	Stairway	2
17	BO-06 axial fan	2
18	Vacuum unit $2 \times 1,5$ m ³	1
19	Screw compressor	1

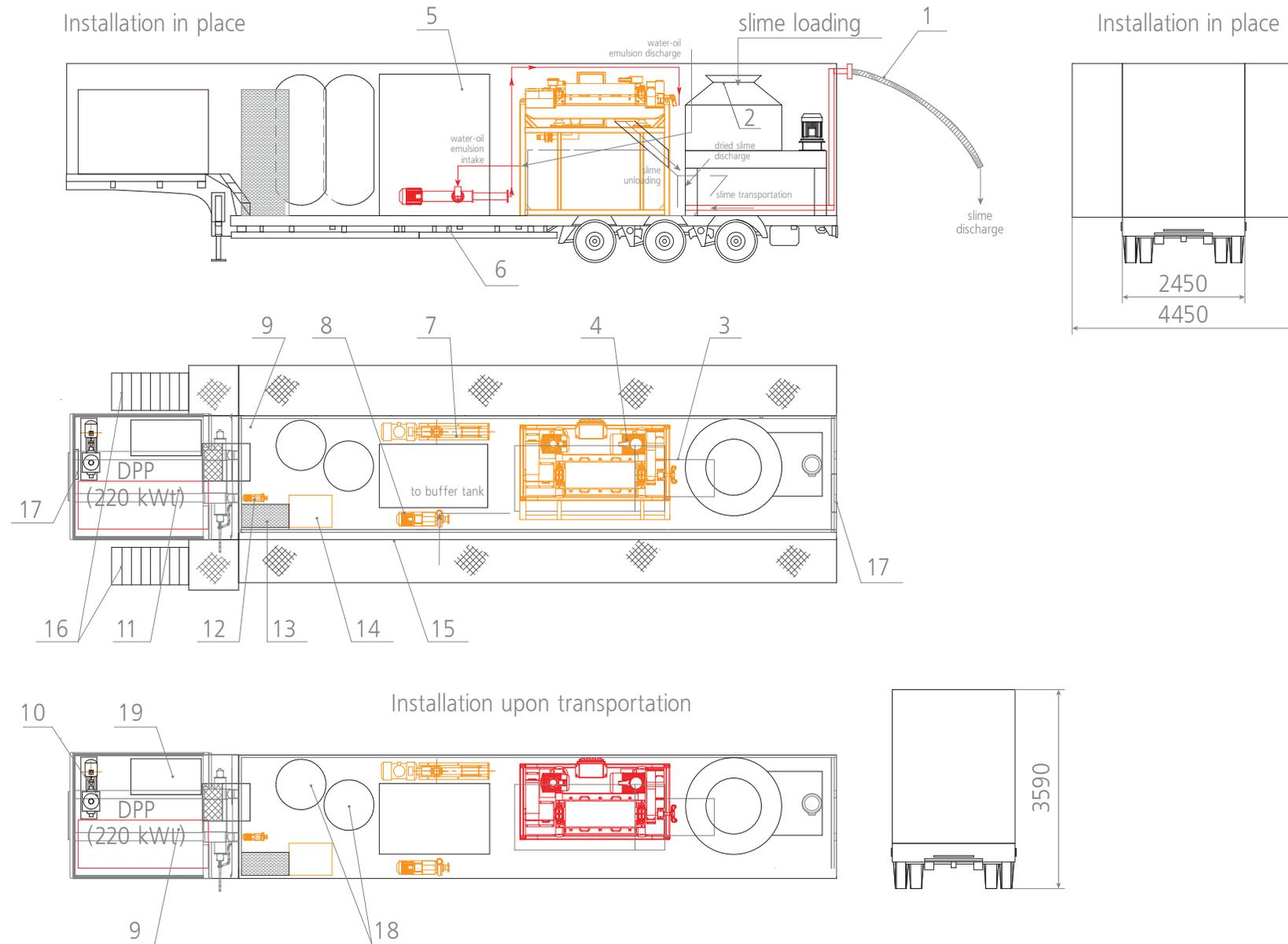

Content of the equipment and technology

3. Unloading unit. Unit of storage and transportation of auxiliary equipment and binders*

The basic equipment consists of a remodeled insulated 40-foot sea container, positioned on its own chassis. The container is equipped with a place for storage of additional equipment, spare parts, petroleum products, tools, places for drying and storing work wear, insulating personal protective equipment.

The space is equipped with lighting, heating and air conditioning systems and allows to work at a temperature from -30 до $+45$ °C.



MARTin complex main view

Pos	Item description	Meas. unit	Quantity
1	Semi-trailer	pc	1
2	40-foot container	pc	1
3	Dining table	pc	1
4	Dresser	pc	1
5	Drying chamber	pc	1
6	Wardrobe with a fan heater	pc	6
7	Shelf stand for spare parts (three-layer)	pc	1
8	Vice bench	set	1
9	Stairway	pc	1
10	Fan*	pc	2
11	Fan heater for drying*	pc	2

* omitted for clarity.

Household units are insulated with mineral wool of S50 mm. Inside lining is made of stainless steel sheet of 0,55 mm.

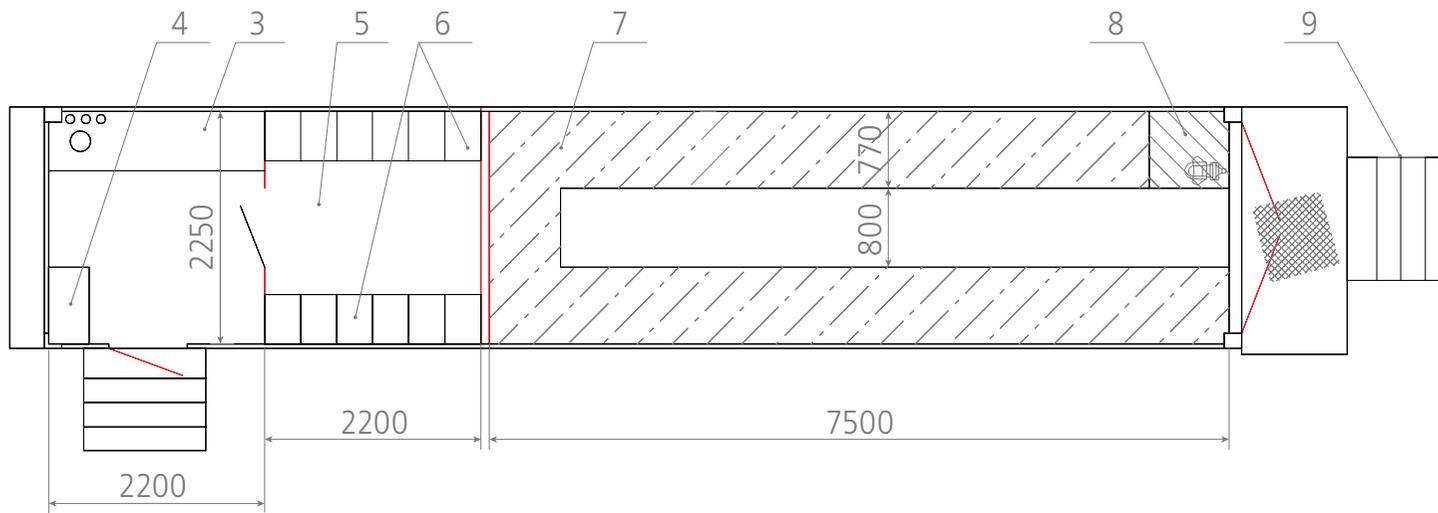
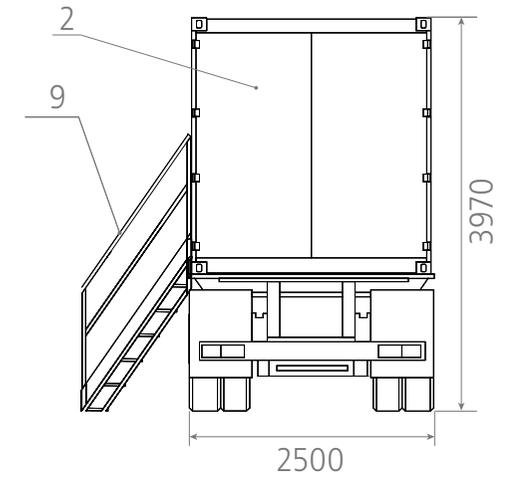
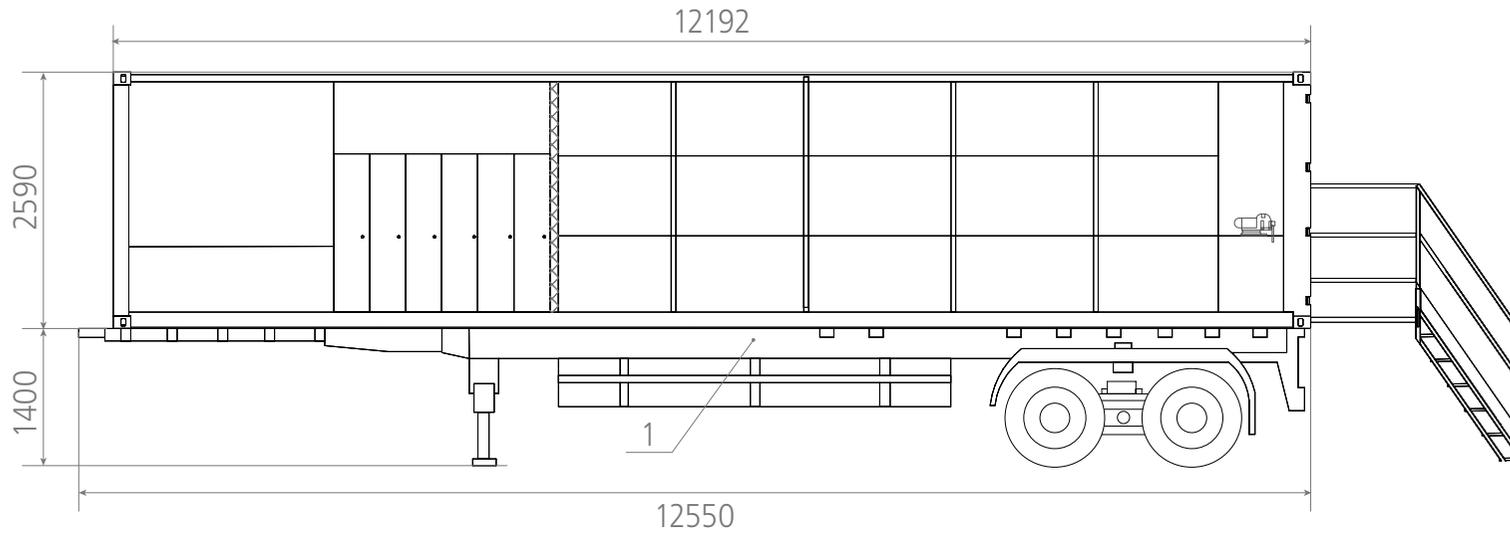

Engineering process

The MARTin complex is transported by tractor trucks to the work site and is installed just beside of the tank. The complex has its own system of installation and alignment of equipment, so installation does not require preparation of the site and crane equipment.



Installation of auxiliary equipment directly in the tank and at the work site is carried out by four specialists of MIRRICO Group of Companies within 4–6 hours after installation of MARTin complex.



To start work, the process tank of the MARTin complex is filled with 30m³ of water and is heated up to 70°C due to the heat-exchanger installed in it. At the same time, a robotic cleaner is brought into the tank. In case of cleaning of a small volume tank, a robotic gun is used instead of a robotic cleaner, a robotic gun is installed on the hatch of the tank by means of a quick-disassembling mechanism. The robotic device is equipped with an extraction pump and a device for washing of sediments with the possibility of feeding a stream of hot water under the pressure up to 20 bar at any angle both horizontally and vertically. With this equipment, the operator remotely cleans the inner surfaces of the tank. Quality of cleaning is assessed through lighting and video surveillance systems.



The extracted liquid with the sediment washed away is transferred by an extraction pump to the cleaning and processing unit. Passing through the coarse treatment unit, emulsion cleaned from large mechanical impurities (up to 25 microns), after passing through a primary refining unit is entered to the centrifugal tricanter, where it is finally separated into cake, water and oil with the use of chemical reagents.



The cake is unloaded into special containers in the unloading unit, and then transported to the landfill, the petroleum product is returned to the customer, and the water obtained enters the treating and processing unit for further use for tanks cleaning.





Innovativeness

Innovativeness of the method

The equipment is cleaned by robotic devices equipped with video surveillance and lighting systems, discharge device and a detergent supply device. The robot is equipped with its own drive, and an operator controls it remotely using a control and monitoring system.

The technology allows to clean any type of equipment:

- rail tanks;
- machnes, separators;
- fractional columns;
- underground storage tanks;
- pipelines;
- tankers.

Mirrico Group of Companies brought together many years of experience in the field of rendering service and chemical solutions for oil and gas industry and developed vertical steel tank cleaning method with subsequent phase separation of the extracted bottom sediments, which is one-and-only in Russia.



Compliance with safety and quality standards

MARTin technology and equipment complies with high safety and quality standards.



Industrial and environmental safety

The equipment of the complex is of hydraulic design, it is fire and explosion proof, has four stages of protection and warning. The technology allows to reduce the amount of oil waste obtained from cleaning of oil tanks, which has beneficial environmental impact of the regions.



Technological effectiveness

Due to the possibility of carrying out work on a 24-hour basis and year-round, the proposed technology allows to reduce significantly the time for cleaning of oil tanks and to increase the period of service in the northern regions.



Health of the personnel

Oil tanks are cleaned with robots, and that is why specialists are not exposed to harmful impact of hydrocarbons.



Economic efficiency

The use of a mobile autonomous robotic complex for cleaning of oil tanks reduces customer's costs for cleaning of vertical steel tanks up to 70%. The technology allows to return to the customer a petroleum product extracted from the bottom oil sediments upon cleaning of vertical steel tanks and to reduce multiply the amount of the oil waste.

Safety and quality



Comparative analysis of unit costs connected with cleaning, disposal and storage of oil slime

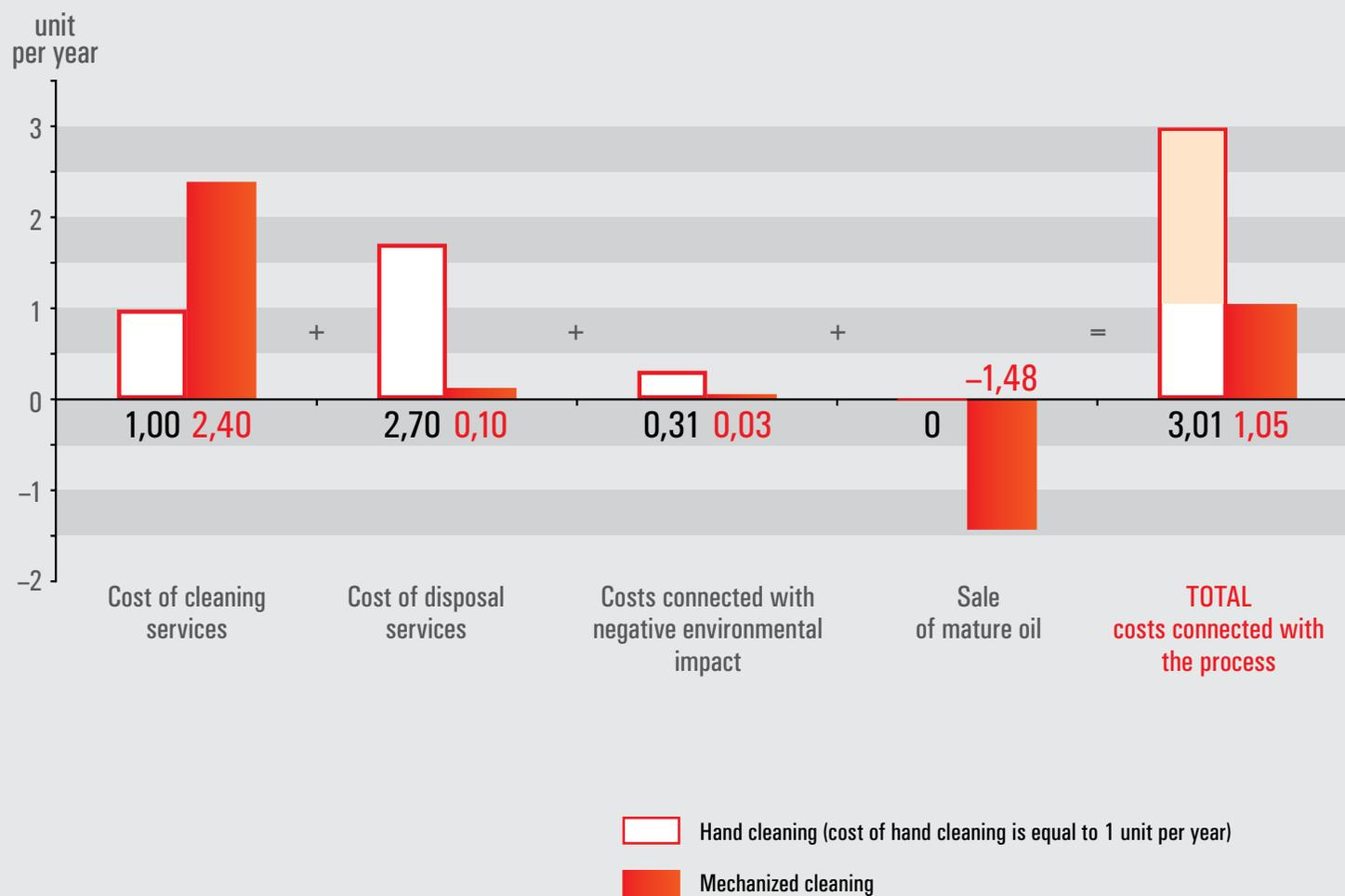

Benefits of MARTin complex

- ▶ Minimization of cleaning time by continuous processing
- ▶ No need of preparation of the ground
- ▶ Minimization of the amount of wastes resulting from tanks cleaning what leads to reduction of costs for disposal of such wastes
- ▶ Potential additional incomes by sale of petroleum products extracted from bottom sediments.
- ▶ 100% health, industrial and environment safety, safety for population and habitats.
- ▶ High quality of cleaning, possibility to perform work inside the tank.
- ▶ Possibility for cleaning at a temperature of -35°C .
- ▶ Possibility to receive information on the course of work online in any part of the world.

Benefits of MARTin complex purchasing in Mirrico Group of Companies

Possibility of supply (sale) of the equipment, which complies with the buyer's requirements.

Our specialists will train the buyer in equipment operation and repair rules.

Warranty maintenance, technical support and spare parts supply.



Conclusion

Mechanized and robotic cleaning methods are the most efficient methods to clean up tanks with a volume of up to 50,000 m³.

Use of cleaning guns is more appropriate for tanks of large volume (50,000 m³ or more) in terms of downtime, which will lead to a reduction of cleaning time by 2–5 times.

A robotic method wins according to cleaning time and gives a 100% guarantee of safety of work in comparison with mechanized method.

Our clients

- NizhnevartovskNefteGaz JSC (TNK)
- Samotlorneftegaz LLC (Rosneft)
- Vankorneft CJSC (Rosneft)
- Gazpromneft-NNG OJSC
- Gazpromneft-Khantos LLC
- Sibur-Khimprom CJSC
- ARKTIKA GAZ OJSC



"...The quality of work allows to make diagnostics the column. Operational stability of the process conditions was ensured as a result of the work. The work was performed in time and without violations of occupational, industrial and fire safety requirements, and in compliance with environmental requirements. The technologies and equipment used is recommended for wide application in chemical and oil facilities of Sibur Holding PJSC."

K.N. Yugov,
Director General of
Sibur-Khimprom CJSC

"...In the course of work performance Drilling Muds Service LLC (Mirrico Group of Companies) proposed and implemented the best technical solutions using the latest technology. According to the results of processing, 200 m³ of water, 42 m³ of oil were returned to the cycle, and the amount of waste to be removed and recycled was reduced. The quality of work allows us to make diagnostics of the tank and its repair with the use of welding equipment."

A.B. Noskov
Chief Engineer of
NizhnevartovskNefteGaz JSC (TNK)

"...A positive factor of the use of this technology in comparison with the manual method of vertical steel tank cleaning is the possibility of extracting oil from bottom sediments, which remains in the ownership of the customer and allows it to ensure a certain payback of the process."

A.M. Uskov
Chief Engineer of Vankorneft CJSC (Rosneft)
Vice-Director General



Patents and licenses



Mirrico Group of Companies



A Russian independent group of Mirrico engineering and service companies carries out activities in the field of complex solutions of technical problems in budget forming industries - oil and gas, oil refining, chemical, petrochemical, mining industry and metallurgy.

The group of companies supplies chemical and technological solutions for production, treatment, transportation, processing of oil, protection of oilfield equipment and pipelines against corrosion and different sediments, construction of gas and water supply wells, enhanced oil recovery, treatment of water rotation cycles of industrial enterprises, improvement of the quality of marketable products and produced water conditioning.

The company has its own production facilities producing chemical products, a research center, a chain of representative offices and warehouses in Russia and the CIS countries, as well as qualified personnel capable to provide work at a high professional level. A distinctive feature of the activities of the Mirrico Group of Companies is a comprehensive approach to problem solving and a focus on the development of innovative products and technologies aimed at increase of economic and technological efficiency of the customer's processes.





MIRRICO

GROUP OF COMPANIES

CONTACT DETAILS:

www.mirrigo.ru

ul. Ostrovskogo, 84, Kazan

Phone +7 (843) 537-23-93

Fax+7 (843) 537-23-94

info@mirrico.com